

Clarke®



185MM, 1200W CIRCULAR SAW (230V)
MODEL NO: CCS185C

PART NO: 6462312

OPERATION & MAINTENANCE INSTRUCTIONS

UK
CA | CE



ORIGINAL INSTRUCTIONS

DL0222

INTRODUCTION

Thank you for purchasing this CLARKE 185mm 1200w (230V) Circular Saw.

Before attempting to use this product, please read this manual thoroughly and follow the instructions carefully. In doing so you will ensure the safety of yourself and that of others around you, and you can look forward to your purchase giving you long and satisfactory service.

GUARANTEE

This product is guaranteed against faulty manufacture for a period of 12 months from the date of purchase. Please keep your receipt which will be required as proof of purchase.

This guarantee is invalid if the product is found to have been abused or tampered with in any way, or not used for the purpose for which it was intended.

Faulty goods should be returned to their place of purchase, no product can be returned to us without prior permission.

This guarantee does not effect your statutory rights.

ENVIRONMENTAL PROTECTION

Recycle unwanted materials instead of disposing of them as waste. All unwanted accessories and packaging should be sorted and taken to a recycling centre for disposal in a manner which is compatible with the environment.

ENVIRONMENTAL RECYCLING POLICY







Through purchase of this product, the customer is taking on the obligation to deal with the WEEE in accordance with the WEEE regulations in relation to the treatment, recycling & recovery and environmentally sound disposal of the WEEE.

In effect, this means that this product must not be disposed of with general household waste but according to the laws governing Waste Electrical and Electronic Equipment (WEEE) at a recognised disposal facility.

SPECIFICATIONS

Model Number	CCS185C
Rated Voltage	230V~50Hz
Power Input	1200W
IP Rating	IPX0
No Load Speed	4500 RPM
Maximum Depth of Cut	65mm @ 90° - 43mm @ 45°
Blade Dimensions	185mm Ø x 2.5mm (thickness) x 20mm Bore
Sound Pressure Level LpA	97dB(A)
Sound Power Level LWA	108dB(A) - Uncertainty Factor (K): 3dB(A)
Vibration	3m/s ² - Uncertainty Factor: 1.5m/s ²
Weight	3.63kg
Dimensions (L x W x H)	280mm x 230mm x 170mm

SAFETY SYMBOLS

	Fully read this manual and safety instructions before use		Eye protection should be worn
	Ear protection should be worn		Dust mask should be worn

PART IDENTIFICATION.

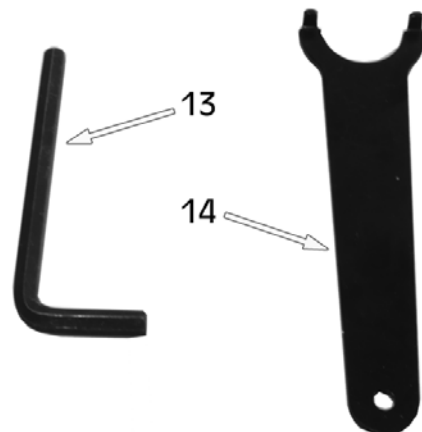
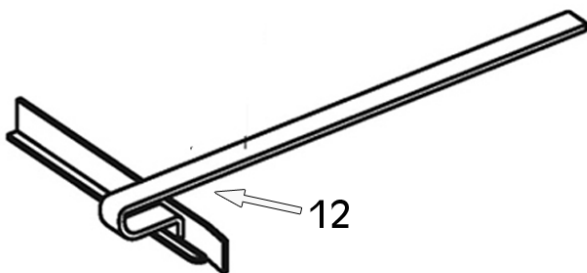
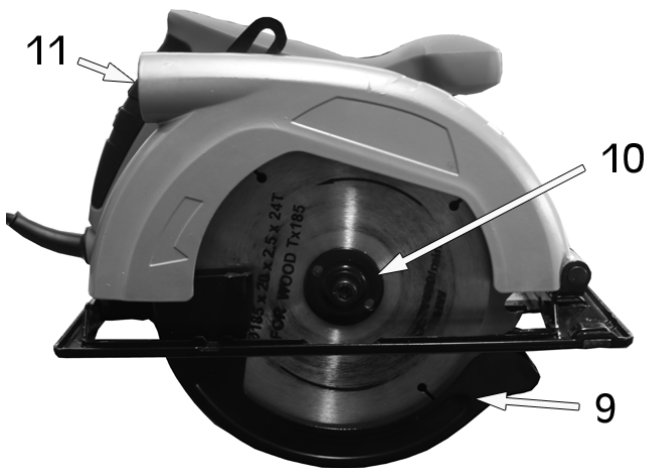
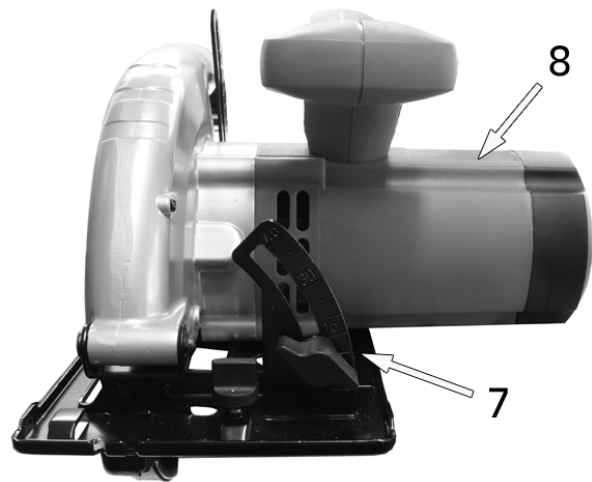
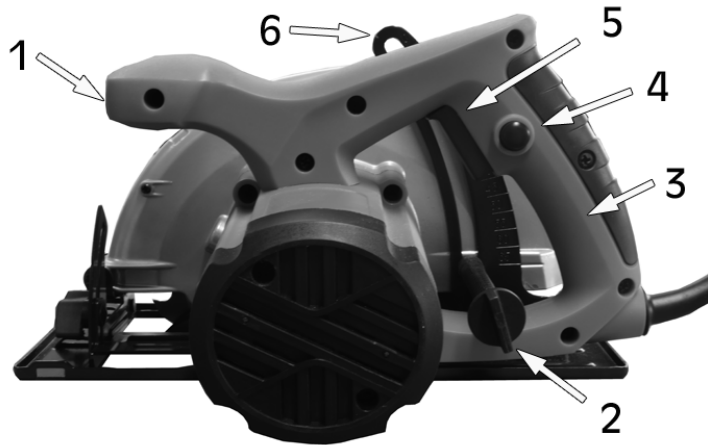

1	Auxiliary Handle	8	Motor
2	Depth Adjustment Screw	9	Lower Blade Guard
3	Handle	10	Blade Clamping Screw
4	Safety Button	11	Dust Extraction Port
5	On/Off Trigger	12	Parallel Guide
6	Depth Adjustment Scale	13	6mm Hexagonal Key
7	Bevel Locking Screw & Scale	14	2 Pin Blade Wrench

CARTON CONTENTS

The following items should be supplied in the carton. If any parts are missing or damaged, please contact the CLARKE dealer where you purchased the tool.

- 1 x 1200 Watt Circular Saw.
- 1 x 185 mm Ø x 20 mm Bore x 24 Tooth TCT blade.
- 1 x Parallel Guide.
- 1 x 6 mm Hexagonal Key.
- 1 x 2 Pin Blade Wrench.

POWER TOOL SAFETY WARNINGS

WORK AREA

1. Keep the work area clean and well lit. Cluttered and dark areas invite accidents.
2. **DO NOT** operate this saw in explosive atmospheres, such as in the presence of flammable liquids, gases or dust. The saw may create sparks which may ignite the dust or fumes.
3. Keep children and bystanders away while operating this saw. Distractions can cause you to lose control.

ELECTRICAL SAFETY

1. The saw plug must match the outlet. **NEVER** modify the plug in any way. **DO NOT** use adaptor plugs with earthed (grounded) power tools. Unmodified plugs and matching outlets will reduce the risk of electric shock.
2. **DO NOT** expose the saw to rain or wet conditions. Water entering the saw will increase the risk of electric shock.
3. **DO NOT** abuse the cable. **NEVER** use it for carrying, pulling or unplugging the saw. Keep the cable away from heat, oil, sharp edges or moving parts. Damaged or entangled cables increase the risk of electric shock.
4. When operating the saw outdoors, use an extension cable suitable for outdoor use. Use of a cable suitable for outdoor use reduces the risk of electric shock.
5. If operating the saw in a damp location is unavoidable, use a residual current device (RCD) protected supply.

PERSONAL SAFETY

1. Stay alert, watch what you are doing and use common sense when operating this saw. **DO NOT** use this saw while you are tired or under the influence of drugs, alcohol or medication. A moment of inattention while operating this saw may result in personal injury.
2. Use safety equipment. **ALWAYS** wear eye protection. Safety equipment such as dust mask, non-skid safety shoes, hard hat, or hearing protection used for appropriate conditions will reduce personal injuries.
3. Avoid accidental starting. Ensure the switch is in the off position before plugging in. Carrying this saw with your finger on the switch or plugging in invites accidents.
4. Remove any wrench before turning the saw on. A wrench left attached to a rotating part may result in personal injury.

5. **DO NOT** overreach. Keep proper footing and balance at all times. This enables better control of the saw in unexpected situations.
6. Dress properly. **DO NOT** wear loose clothing or jewellery. Keep your hair, clothing and gloves away from moving parts. Loose clothes, jewellery or long hair can be caught in moving parts.

POWER TOOL USE AND CARE

1. **DO NOT** force the saw. Use the correct accessories for your application. The correct power tool will do the job better and safer at the rate which it was designed for.
2. **DO NOT** use the saw if the switch does not turn it on and/or off. Any power tool that cannot be controlled with the switch is dangerous and **SHOULD NOT** be used until it has been repaired.
3. Disconnect the plug from the power source before changing accessories, or storing the saw. Such preventive safety measures reduce the risk of starting the saw accidentally.
4. Store idle tools out of the reach of children and **DO NOT** allow persons unfamiliar with the saw or these instructions to operate it. Power tools are dangerous in the hands of untrained users.
5. Maintain power tools. Check for misalignment or binding of moving parts, breakage of parts and any other condition that may affect the saw's operation. If damaged, have the saw repaired before use. Many accidents are caused by poorly maintained power tools.
6. Use the power tool and accessories in accordance with these instructions and in the manner intended, taking into account the working conditions and the work to be performed. Use of the saw for operations different from intended could result in a hazardous situation.
7. The performance of this saw may vary, depending upon variations in line voltage. Extension cable usage may also affect performance.

SERVICE

1. Have your saw serviced by qualified service personnel using only identical replacement parts. This will ensure that the safety of the saw is maintained.

SAFETY INSTRUCTIONS FOR ALL SAWS

1. Keep hands away from cutting area and the blade. Keep your second hand on the auxiliary handle, or motor housing. If both hands are holding the saw, they cannot be cut by the blade.
2. **DO NOT** reach underneath the workpiece. The guard cannot protect you from the blade below the workpiece.
3. Adjust the cutting depth to the thickness of the workpiece. Less than a full tooth of the blade teeth should be visible below the workpiece.
4. **NEVER** hold the work piece being cut in your hands or across your leg. Secure the workpiece to a stable platform. It is important to support the work properly to minimise body exposure, blade binding, or loss of control.
5. **ALWAYS** hold the saw by the insulated handles when performing an operation (see page 13). Contact with a live wire may make exposed metal parts of the saw live and shock the operator.
6. **ALWAYS** use blades with the correct size and shape of arbor holes. Blades that do not match the mounting hardware of the saw will run eccentrically, causing loss of control.
7. **NEVER** use damaged or incorrect blade washers or bolt. The blade washers and bolt were specially designed for your saw, for optimum performance and safety of operation.
8. **DO NOT** operate the saw if the guards are damaged or do not operate correctly.
9. **NEVER** use the saw with the guards removed.

CIRCULAR SAW BLADE SAFETY WARNINGS

1. The maximum speed listed for the saw (see page 3) should not exceed the maximum speed marked on the blade.
2. Cracked circular saw blades should be scrapped (repairing is not permitted). Composite (tipped) circular saw blades, where the tip dimension is reduced to less than 1mm, should be taken out of service.
3. Fastening screws and nuts should be tightened using the tools supplied.
4. Clamping surfaces should be cleaned to remove dirt, grease, oil and water.
5. **DO NOT** use loose rings or bushes to “make up” bore sizes on circular saw blades.

PREVENTION OF KICKBACK

Kickback is a sudden reaction to a pinched, bound or misaligned saw blade, causing an uncontrolled saw to lift up and out of the workpiece toward the operator.

When the blade is pinched or bound tightly by the kerf closing down, the blade stalls and the motor reaction drives the unit rapidly back toward the operator.

If the blade becomes twisted or misaligned in the cut, the teeth at the back edge of the blade can dig into the top surface of the wood causing the blade to climb out of the kerf and jump back toward the operator. Kickback is the result of saw misuse and/or incorrect operating procedures or conditions and can be avoided by taking proper precautions as given below.

1. Maintain a firm grip with both hands on the saw and position your arms to resist kickback forces. Position your body to either side of the blade, but not in line with the blade.
2. When the blade is binding, or when interrupting a cut for any reason, release the trigger and hold the saw motionless in the material until the blade comes to a complete stop. **NEVER** attempt to remove the saw from the work or pull the saw backward while the blade is in motion or kickback may occur. Investigate and take corrective actions to eliminate the cause of blade binding.
3. When restarting a saw in the workpiece, centre the saw blade in the kerf and check that saw teeth are not engaged with the material. If the blade is binding, it may walk up or kickback from the workpiece as the saw is restarted.
4. Support large panels to minimise the risk of blade pinching and kickback. Large panels tend to sag under their own weight. Supports must be placed under the panel on both sides, near the line of cut and near the edge of the panel.
5. Blade depth and bevel adjusting locking screws must be tight and secure before making a cut. If blade adjustment shifts while cutting, it may cause binding and kickback.
6. Use extra caution when making a "plunge cut" into existing walls or other blind areas. The protruding blade may cut objects that can cause kickback.

ELECTRICAL CONNECTIONS



WARNING: READ THESE ELECTRICAL SAFETY INSTRUCTIONS THOROUGHLY BEFORE CONNECTING THE PRODUCT TO THE MAINS SUPPLY.

Before switching the product on, make sure that the voltage of your electricity supply is the same as that indicated on the rating plate. This product is designed to operate on 230VAC 50Hz. Connecting it to any other power source may cause damage.

This product may be fitted with a non-rewireable plug. If it is necessary to change the fuse in the plug, the fuse cover must be refitted. If the fuse cover becomes lost or damaged, the plug must not be used until a suitable replacement is obtained.

If the plug has to be changed because it is not suitable for your socket, or due to damage, it should be cut off and a replacement fitted, following the wiring instructions shown below. The old plug must be disposed of safely, as insertion into a mains socket could cause an electrical hazard.

If the colours of the wires in the power cable of this product do not correspond with the markings on the terminals of your plug, proceed as follows.

- The wire which is coloured **Blue** must be connected to the terminal which is marked **N** or coloured **Black**.
- The wire which is coloured **Brown** must be connected to the terminal which is marked **L** or coloured **Red**.

Plug must be BS1363/A approved.

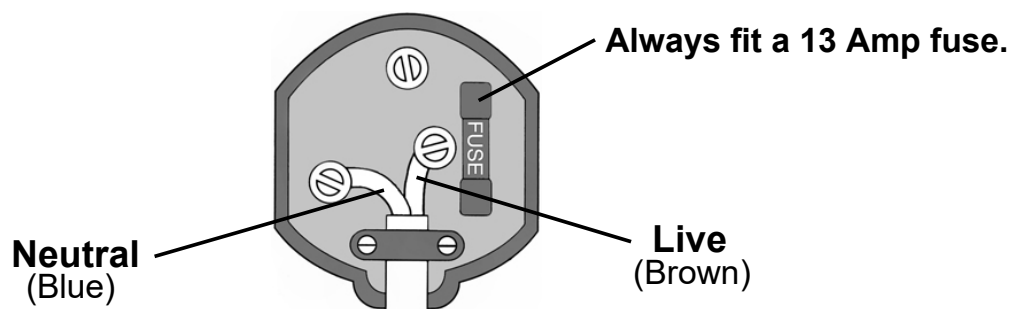

Ensure that the outer sheath of the cable is firmly held by the clamp

We strongly recommend that this machine is connected to the mains supply via a Residual Current Device (RCD)



This symbol indicates that this is a Class II product, and does not require an earth connection.

ADJUSTMENTS

DEPTH OF CUT ADJUSTMENT

1. Loosen the depth adjustment screw.
2. Adjust the base plate until the required depth of blade is protruding through the base plate.
3. Tighten the depth adjustment screw.

NOTE: For optimum results, a full tooth should just be visible below the workpiece.

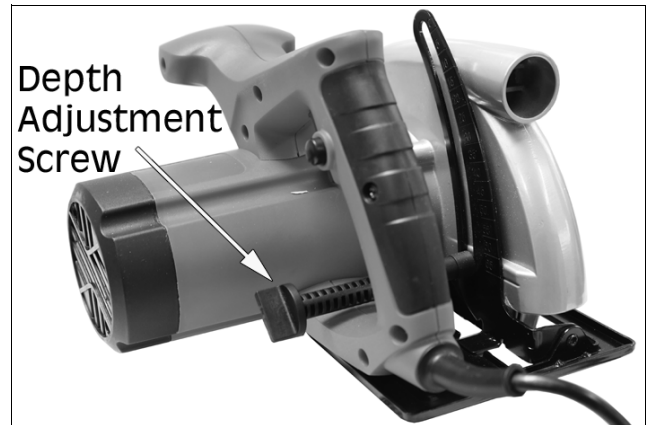

BEVEL ADJUSTMENT

1. Loosen the bevel adjustment locking screw.
2. Adjust the base plate to the required angle (max 45°)
 - Use the bevel scale as a guide only, for accurate angles use a protractor.
3. Tighten the bevel adjustment locking screw to secure.

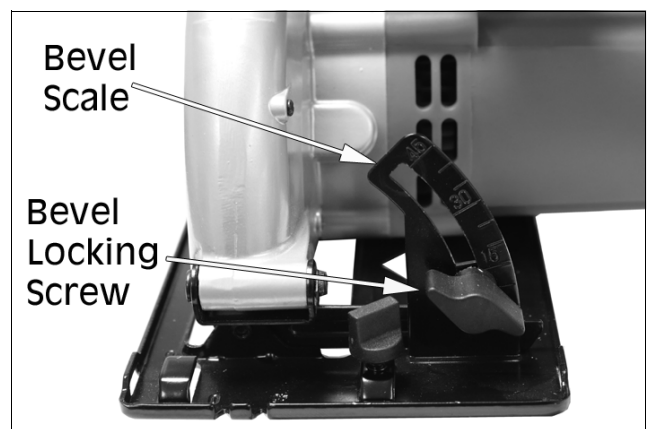

MOUNTING AND USING THE PARALLEL GUIDE

MOUNTING

1. Slide the parallel guide into the base plate as shown.
2. Secure in place using the parallel guide locking screw.

ADJUSTING

1. Loosen the Parallel Guide Locking Screw.
2. Adjust the Parallel Guide to the required length.
 - There is a scale on the parallel guide that can be used to give an approximate guide. Always double check using an accurate ruler.
3. Tighten the Parallel Guide Locking Screw to secure the parallel guide in position.

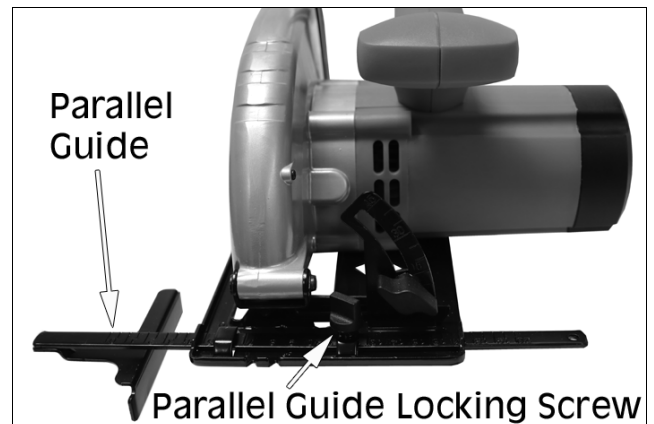

DUST EXTRACTION

The circular saw can be connected to a dust extraction system, using a suitable hose adaptor (not supplied).

- The internal diameter of the dust extraction outlet is 28 mm.



OPERATION & USE

CORRECT HAND POSITION

For your own safety, always hold the circular saw as shown in this picture, with your right hand on the main handle and your left hand on the auxiliary handle.



SWITCHING ON/OFF

The on/off trigger is fitted with a safety button which prevents the circular saw from being started accidentally. To start the saw:

1. Press and hold the safety button.
2. Squeeze the on/off trigger at the same time.
3. Release the on/off trigger to stop the saw.
4. The blade will continue to rotate for several seconds after the trigger has been released.

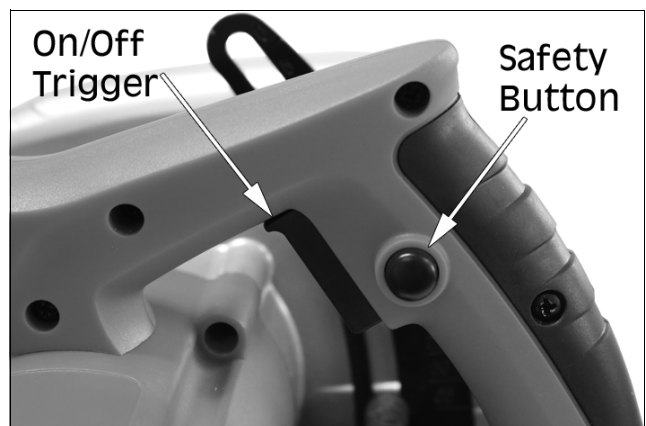

GUIDING THE CIRCULAR SAW

To achieve optimal results:

- Clamp the workpiece upside down to the workbench to minimise breakout.
- Follow the line drawn on the workpiece using the 0 mark (90° to the horizontal).
- If cutting a bevel angle of 45°, follow the line drawn on the workpiece using the 45 mark.

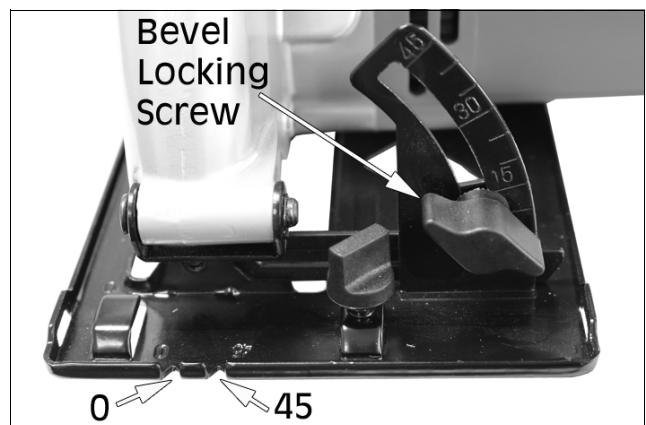

MAINTENANCE



WARNING: DISCONNECT THE CIRCULAR SAW FROM THE MAINS SUPPLY BEFORE FITTING REPLACEMENT BLADES, CLEANING OR ADJUSTMENT.

Keep the machine clean by wiping off dust with a clean cloth.

BLADE REPLACEMENT

1. Place the 2 pin blade wrench in the 2 holes on the blade clamping screw. Remove the blade clamping screw using the 6mm hex key by turning it anti-clockwise while holding the 2 pin wrench in place.

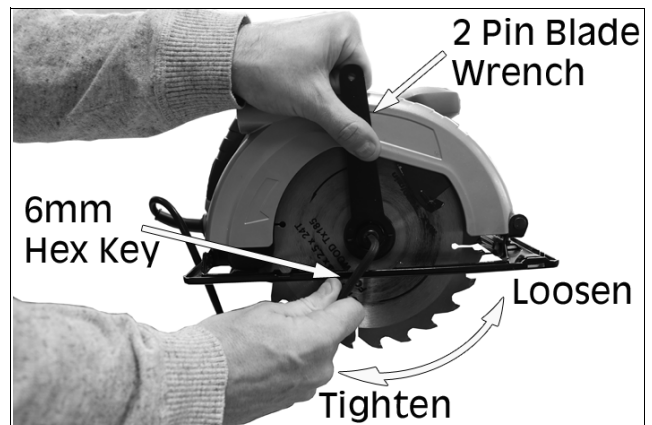

2. Retract the lower blade guard using the retracting lever and replace the blade.
 - Make sure you pay attention to the blade direction markings on the blade.
 - Spare blades are available from your local CLARKE dealer.

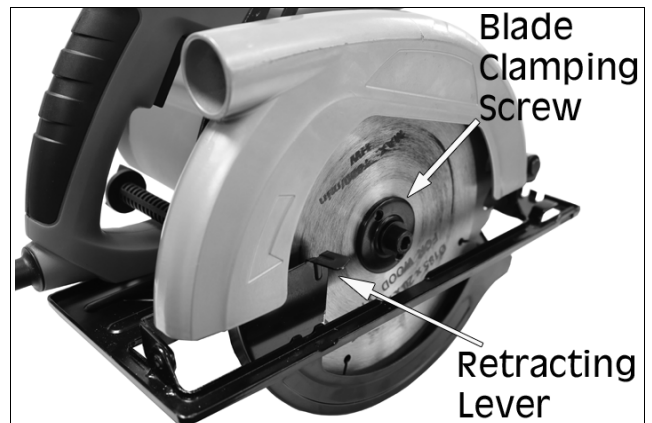

3. Replace the blade clamping screw by hand until it is holding the blade in position.
4. Place the 2 pin blade wrench in the 2 holes on the blade clamping screw.
5. Tighten the blade clamping screw using the hex key by turning it clockwise while holding the 2 pin blade wrench in place.

Replacement blades can be purchased from your local CLARKE dealer.

- CLARKE 185mm TCT Circular Saw Blade 24 tooth, Part No. 6490045

DECLARATION OF CONFORMITY



Hemmill Street, Epping, Essex CM16 4LG

DECLARATION OF CONFORMITY

This is an important document and should be retained.

We hereby declare that this product(s) complies with the following statutory requirement(s):

- Supply of Machinery (Safety) Regulations 2008
- Electromagnetic Compatibility Regulations 2016
- The Restriction of the Use of Certain Hazardous Substances in Electrical and Electronic Equipment Regulations 2012

The following standards have been applied to the product(s):

- EN 60745-2-5:2010, EN 60745-1:2009+A11:2010, EN 60825-1:2014, EN 62841-1:2015+AC:15,
- EN 62841-2-5:2014, EN 55014-1:2017, EN 55014-2:2015, EN 61000-3-2:2019,
- EN 61000-3-3:2013+A1:2019, IEC 62321-2:2008, IEC 62321-7-1:2015, IEC 62321-4:2013,
- IEC 62321-5:2013, IEC 62321-6:2015.

The technical documentation required to demonstrate that the product(s) meet(s) the requirement(s) of the aforementioned legislation has been compiled and is available for inspection by the relevant enforcement authorities.

The UKCA mark was first applied in: 2022

Product Description: 185mm Circular Saw 1200W
Model number(s): CCS185C
Serial / batch Number: N/A
Date of issue: 09/02/2022

Signed:

J.A. Clarke
Director

CCS185C UKCA Clarke DOC 020922

Page 1 of 1



Fitzwilliam Hall, Fitzwilliam Place, Dublin 2

DECLARATION OF CONFORMITY

This is an important document and should be retained.

We hereby declare that this product(s) complies with the following directive(s):

- 2006/42/EC Machinery Directive
- 2014/30/EU Electromagnetic Compatibility Directive
- 2011/65/EU Restriction of Hazardous substances

The following standards have been applied to the product(s):

- EN 60745-2-5:2010, EN 60745-1:2009+A11:2010, EN 60825-1:2014, EN 62841-1:2015+AC:15,
- EN 62841-2-5:2014, EN 55014-1:2017, EN 55014-2:2015, EN 61000-3-2:2019,
- EN 61000-3-3:2013+A1:2019, IEC 62321-2:2008, IEC 62321-7-1:2015, IEC 62321-4:2013,
- IEC 62321-5:2013, IEC 62321-6:2015.

The technical documentation required to demonstrate that the product(s) meet(s) the requirement(s) of the aforementioned directive(s) has been compiled and is available for inspection by the relevant enforcement authorities.

The CE mark was first applied in: 2022

Product Description: 185mm Circular Saw 1200W
Model number(s): CCS185C
Serial / batch Number: N/A
Date of issue: 09/02/2022

Signed:

J.A. Clarke
Director

CCS185C CE Clarke DOC 020922

Page 1 of 1

A SELECTION FROM THE VAST RANGE OF

Clarke®

QUALITY PRODUCTS



AIR COMPRESSORS
From DIY to industrial, Plus air tools, spray guns and accessories.

GENERATORS
Prime duty or emergency standby for business, home and leisure.

POWER WASHERS
Hot and cold, electric and engine driven - we have what you need

WELDERS
Mig, Arc, Tig and Spot. From DIY to auto/industrial.

METALWORKING
Drills, grinders and saws for DIY and professional use.

WOODWORKING
Saws, sanders, lathes, mortisers and dust extraction.

HYDRAULICS
Cranes, body repair kits, transmission jacks for all types of workshop use.

WATER PUMPS
Submersible, electric and engine driven for DIY, agriculture and industry.

POWERTOOLS
Angle grinders, cordless drill sets, saws and sanders.

STARTERS/CHARGERS
All sizes for car and commercial use.



PARTS & SERVICE: 0208 988 7400

Parts Enquiries
Parts@clarkeinternational.com

Servicing & Technical Enquiries
Service@clarkeinternational.com

SALES: UK 01992 565333 or Export 00 44 (0)1992 565335

Clarke® INTERNATIONAL Hemnall Street, Epping, Essex CM16 4LG
www.clarkeinternational.com